

# Circuit Diagram

## APEX 49B

Models: PB40BL & PB40BH



Valid from: October 22, 2004

Updated: October 8, 2009

Electrical parts reference list for Apex 49.

Refer to parts manual for detailed assembly drawing.

X part numbers for connectors reference the components side only.

Ref.	Description	Part Number	Path
A1	Drive controller	01130760	6.10
B1	Pressure switch, Filter clog	01133980	4.21
E1	Lights, Front left (OPTION)	90417932	4.16
E2	Lights, Front right (OPTION)	Part of E1	4.18
E4	Lights, Rear left (OPTION)	90417932	4.21
E5	Lights, Rear right (OPTION)	Part of E3	4.23
F1	Fuse, 63A- Drive controller	01056100	6.10
F2	Fuse, 20A- Main fuse battery (pre-fuse)	00500360	7.4
F3	Fuse, 10A- Drive control unit	00733630	7.6
F4	Fuse, 5A- Dash board, Rear light right	00906120	7.8
F5	Fuse, 10A- Horn	00733630	7.10
F6	Fuse, 5A- Cylindrical Motor control	00906120	7.11
F7	Fuse, 5A- Z1 Battery discharge indicator	00906120	7.13
F8	Fuse, 7.5A- Lights	00509550	7.15
F9	Fuse, 7.5A- High dump	00509550	7.17
F10	Fuse, 30A- Vacuum wand (OPTION- 6509)	00152060	7.19
F11	Fuse, 30A- Shaker motor	00152060	7.21
F12	Fuse, 63A- Cylindrical motor	01056100	7.23
F13	Fuse, 30A- Hydraulic motor- M4 (high dump)	01134450	7.24
F14	Fuse, 5A Flash light (OPTION- 6505)	00906120	7.22
G1	Battery, 24V (6V- 235Ah 4 needed)	956740	3.2
H1	Indicator lamp, Parking brake	01132920	3.10
H2	Indicator lamp, Filter clog- shaker/blower	01132900	3.10
H3	Indicator lamp, Drive controller error	Part of H1	3.12
H4	Indicator lamp, Filter flap	Part of H2	3.12
H5	Horn	01133200	4.12
H7	Warning beacon (OPTION- 6505)	Part of 6505	4.13
K1	Relay, Speed reduction (Multimode)	00965030	6.17
K2	Solenoid, Cylindrical broom motor- M2	00750210	6.23
K3	Relay, M2 cut off (discharge point)	00965030	6.17
K4	Timer relay, Filter clogging	01133180	6.19
K5	Pulse relay, Shaker motor	01133170	6.23
	HIGH DUMP items on PB40BH ONLY		

Ref.	Description	Part Number	Path
K6	Relay, High dump	00965030	7.14
K7	Relay, High dump	00965030	7.18
K8	Relay, High dump	00965030	7.22
K9	Relay, High dump	00965030	7.26
K10	Contactor, Reversing- Lift (high dump)	01134480	7.17
K11	Contactor, Reversing- Lower (high dump)	Part of K10	7.17
K12	Relay, Speed reduction (discharge)	00965030	6.23
M1	Drive motor	01132780	3.24
M1.S1	Thermal switch, Drive motor	01135530	3.25
M2	Cylindrical broom motor	01133130	3.19
M2.S1	Thermal switch, Cylindrical broom	01133140	3.21
M3	Shaker motor	01000890	4.33
M4	Hydraulic motor (high dump)	01135070	7.2
M5	Vacuum motor (OPTION- 6509)	90422692	4.26
R1	Drive potentiometer (turn angle trans)	00975500	3.15
R2	Resistor, 7kΩ	19245034	6.20
S1	Key Switch	90323437	3.5
S2	Reverse switch (micro switch)	00975510	3.16
S3	Forward switch (micro switch)	00975510	3.15
S4	Hopper (down) switch (push switch) (high dump)	00927610	4.5
S5	Seat switch (contact switch)	01073290	4.9
S6	Cylindrical broom switch (micro switch)	00975510	4.2
S7	Parking brake switch (push switch)	00927610	4.2
S8	Warning beacon (rocker switch) (OPTION- 6505)	19256082	3.4
S9	Horn switch (push rocker)	01132970	3.7
S10	Shaker switch (micro switch)	00975510	3.7
S11	Filter flap switch (micro switch)	00975510	4.19
S12	Flood light switch(rocker switch) (OPTION)	01135290	3.7
S14	Hopper move switch (push button) (high dump)	01134370	3.14
S15	Hopper lift/lower switch (rocker switch)(high dump)	01134360	3.11
V1	Diode, Horn	90194879	4.13
V2	Diode, High dump relay	90194879	7.26
	RED= NON-Stock Item		



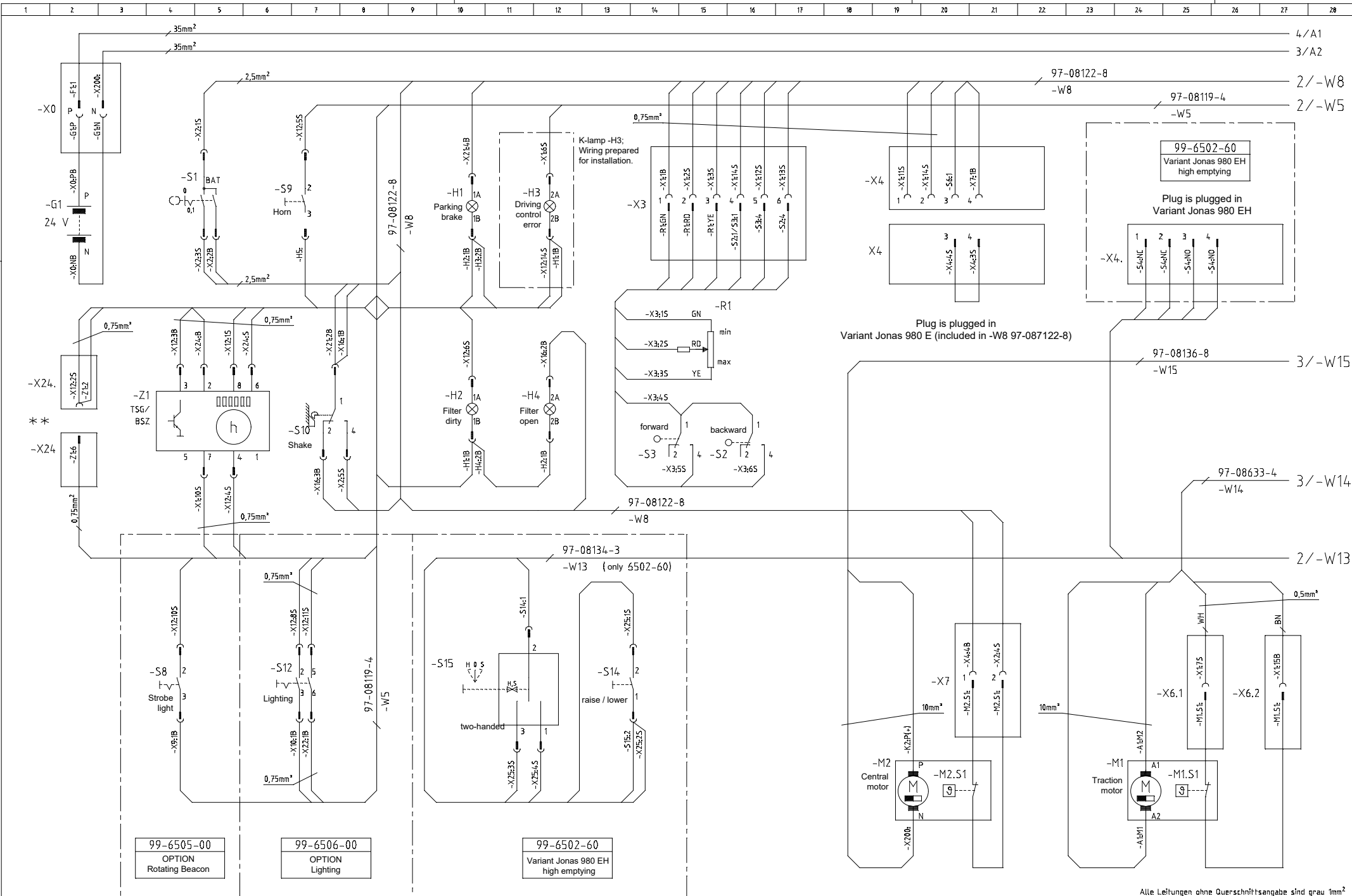

\*\* Note:  
Plug connector - X24 together for configuration mode TSG.

99-6505-00  
OPTION  
Rotating Beacon

99-6506-00  
OPTION  
Lighting

99-6502-60  
Variant Jonas 980 EH  
high emptying

99-6502-60  
Variant Jonas 980 EH  
high emptying

Plug is plugged in  
Variant Jonas 980 EH

Plug is plugged in  
Variant Jonas 980 E (included in -W8 97-087122-8)

97-08633-4  
-W14  
3/-W14

97-08136-8  
-W15  
3/-W15

97-08119-4  
-W5  
2/-W5

97-08122-8  
-W8  
2/-W8

97-08122-8  
-W8  
2/-W5

97-08122-8  
-W8  
2/-W5

97-08122-8  
-W8  
2/-W5

97-08122-8  
-W8  
2/-W5

97-08122-8  
-W8  
2/-W5

97-08122-8  
-W8  
2/-W5

97-08122-8  
-W8  
2/-W5

97-08122-8  
-W8  
2/-W5

Alle Leitungen ohne Querschnittsangabe sind grau 1mm<sup>2</sup>

=		6	/.	0190-01	20.10.04	MP.	2003	Datum	Name	VES-Nr. :	Benennung		Zeichnungs-Nr.	
+		Nr.	Zahl kommt vor	Änd.-Nr.	Datum	Name	Gezeichnet	20.05.	MP	Ersatz für:	CIRCUIT DIAGRAM APEX 49B		91-02101-4	
							Geprüft			Änd. Nr. :	Für diese Zeichnung behalten wir uns alle Rechte vor. Gemäß DIN 341		Blattzahl: 8   Blatt: 3	
							Normgepr.			004.1-22	Typ: 6502-60/60			

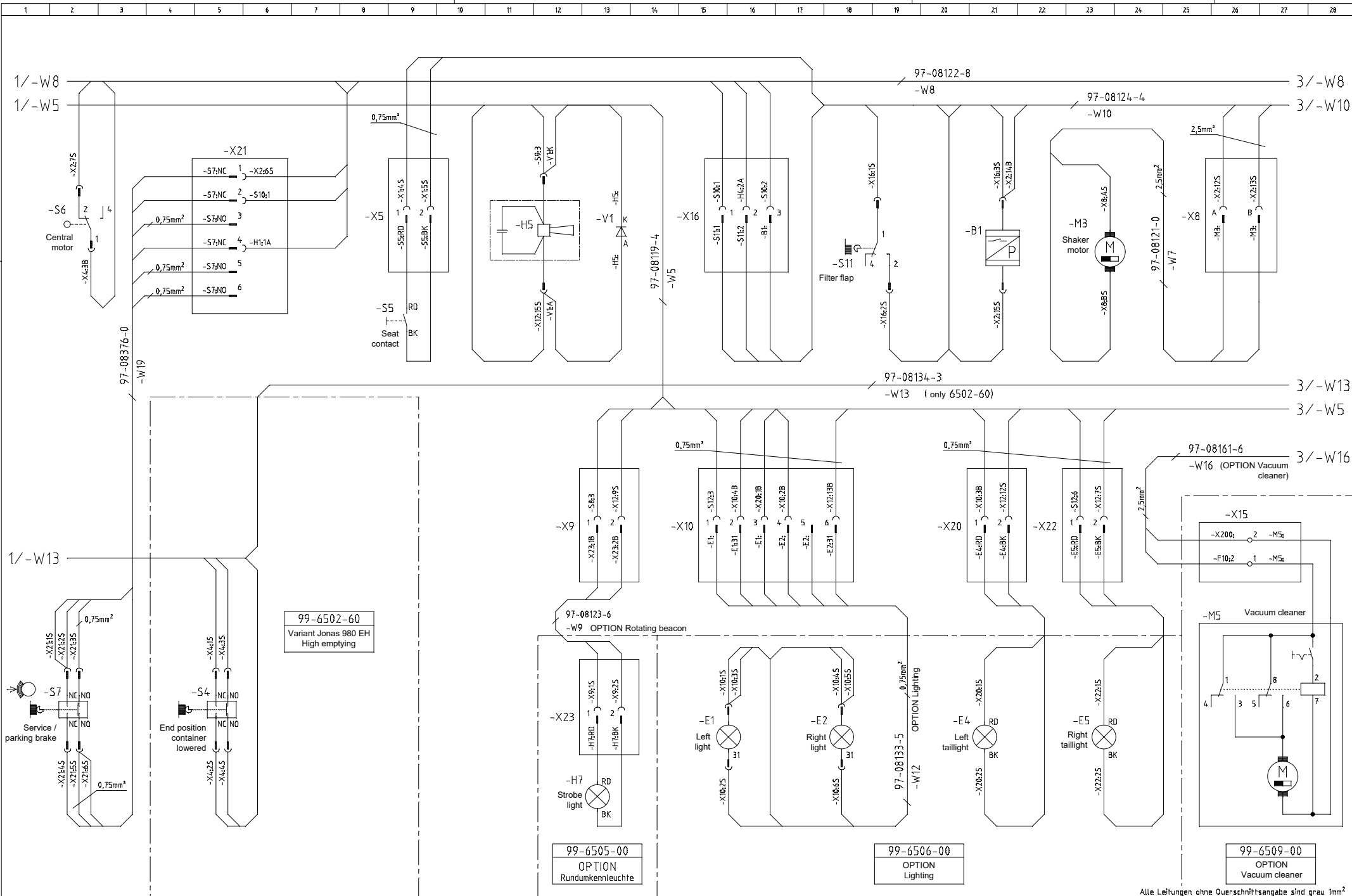

Alle Leitungen ohne Querschnittsangaben sind grau 1mm²

=	6	.	0190-01	20.10.04	MP.	2003	Datum	Name	VES-Nr. :	Benennung		Zeichnungs-Nr. 91-02101-4
	Gezeichnet		20.05.		MP	Ersatz für:		GLNr.		CIRCUIT DIAGRAM APEX 49B		
+	Nr. Zahl kommt vor		Änd.-Nr.	Datum	Name	Normgepr.	Änd. Nr. :		004.1-22		Für diese Zeichnung behalten wir uns alle Rechte vor. (Gemäß DIN 34)	
											Typ: 6502-60/60 Blattzahl: 8 Blatt: 4	

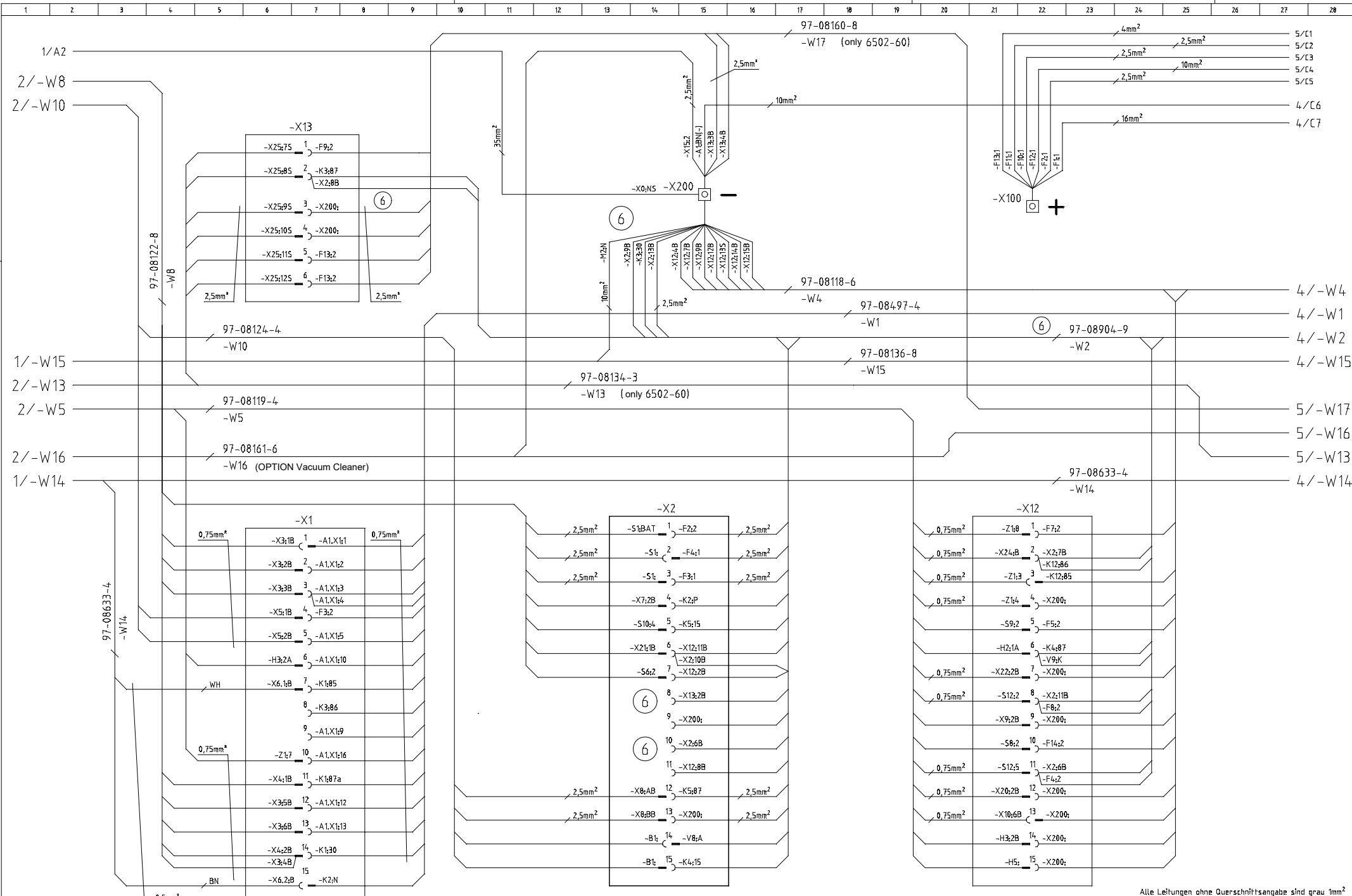

Alle Leitungen ohne Querschnittsangabe sind grau 1mm²

=	6	5x	0190-01	20.10.04	MP.	2003	Datum	Name	VES-Nr. :	Benennung		Zeichnungs-Nr. 91-02101-4	
	Gezeichnet		20.05.		MP	Ersatz für:		GLNr.		CIRCUIT DIAGRAM APEX 49B			
+	Nr. Zahl kommt vor		Änd.-Nr.	Datum	Name	Normgepr.	Änd. Nr. :		004.1-22		Für diese Zeichnung behalten wir uns alle Rechte vor. (Gemäß DIN 34)	Typ: 6502-60/60	Blattzahl: 8   Blatt: 5

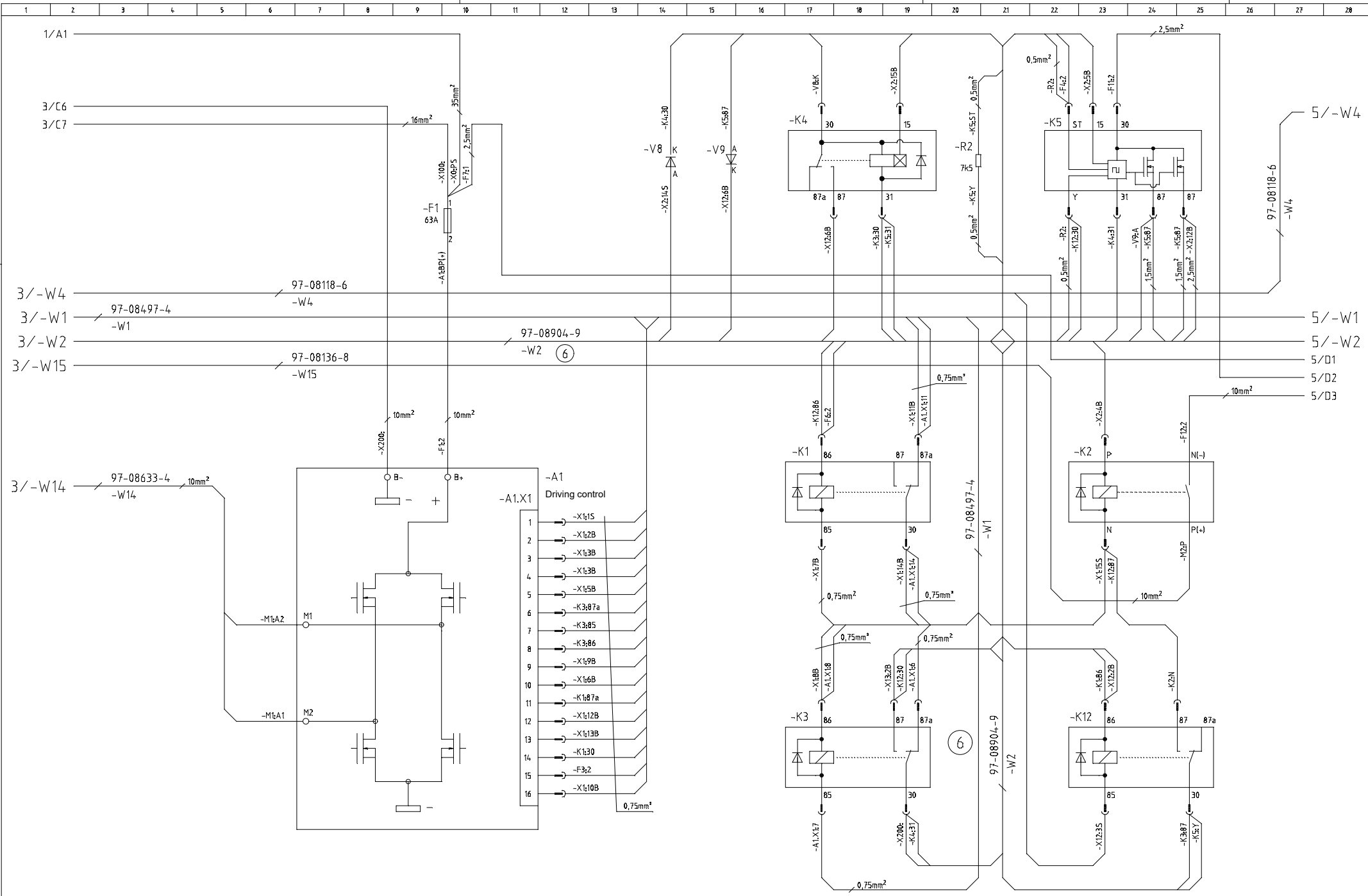

Alle Leitungen ohne Querschnittsangabe sind grau 1mm²

=	6	Zx	0190-01	20.10.04	MP.	2003 Gezeichnet Geprüft	Datum 20.05. MP	Name	VES-Nr. :	Benennung	Alle Leitungen ohne Querschnittsangabe sind grau 1mm²		Zeichnungs-Nr.
	+	Nr. Zahl kommt vor	Änd.-Nr.	Datum	Name	Normgepr.			Ersatz für: GLNr.	<b>CIRCUIT DIAGRAM APEX 498</b>	<b>PowerBoss</b>	91-02101-4	
									Änd. Nr. : 004.1-22	Für diese Zeichnung behalten wir uns alle Rechte vor. (Gem. §9 DIN 34)	Typ: 6502-60/60	Blattzahl: 8 Blatt: 6	

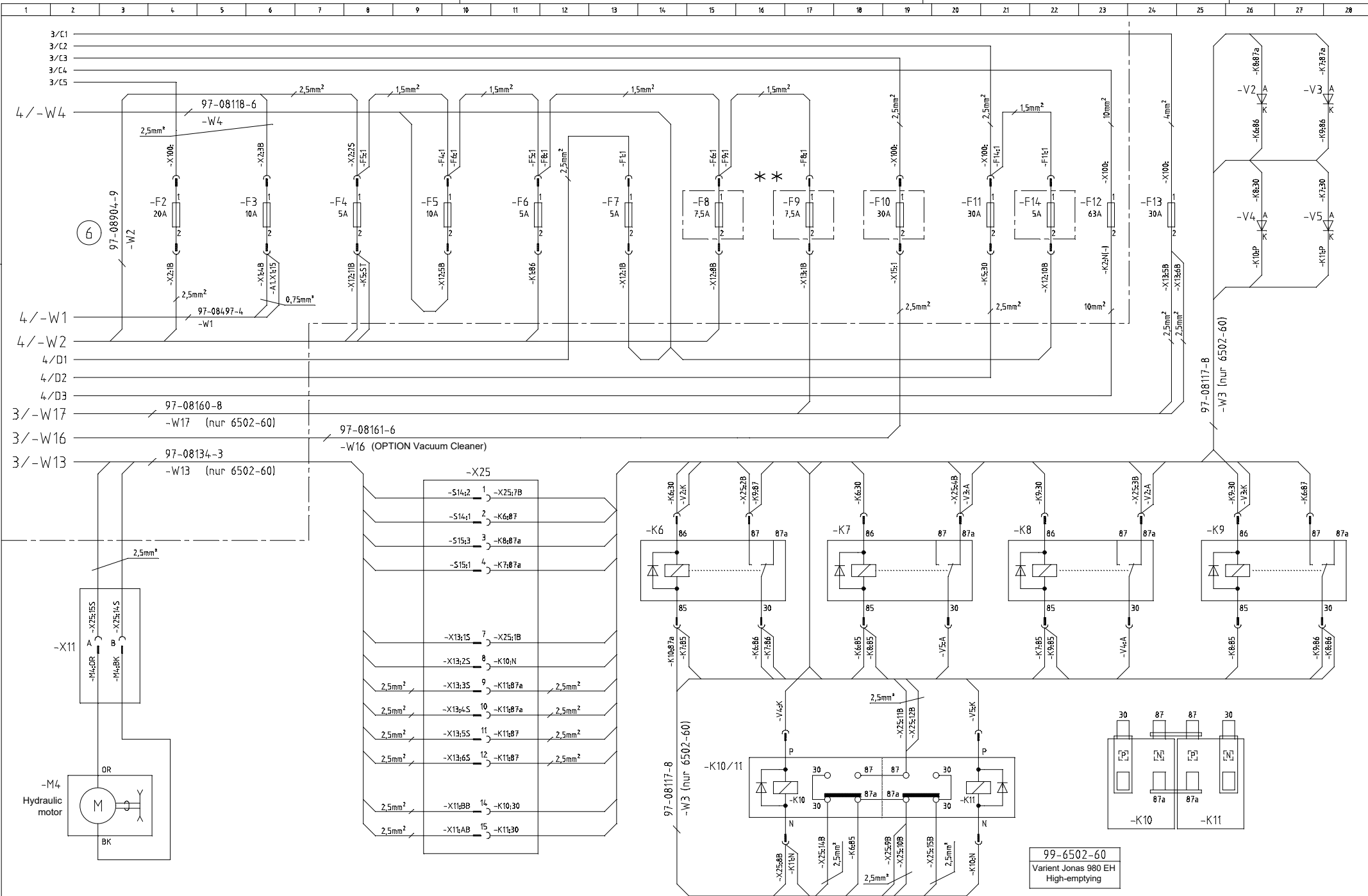

\*\* Note:  
Fuses assigned to the respective  
OPTION (see reference list)

99-6502-60  
Variant Jonas 980 EH  
High-emptying

Alle Leitungen ohne Querschnittsangebe sind grau 1mm<sup>2</sup>

=	6	1x	0190-01	20.10.04	MP.	2003	Datum	Name	VES-Nr. :	Benennung		Zeichnungs-Nr. 91-02101-4	
	Gezeichnet		20.05.		MP	Ersatz für:		GLNr.		<b>CIRCUIT DIAGRAM APEX 498</b>			
+	Nr. Zahl kommt vor		Änd.-Nr.	Datum	Name	Normgepr.	Änd. Nr. :		004.1-22		Für diese Zeichnung behalten wir uns alle Rechte vor. (Gemäß DIN 34)		
											Typ: 6502-60/60	Blattzahl: 8	Blatt: 7

